

Compact
permanent magnet generators

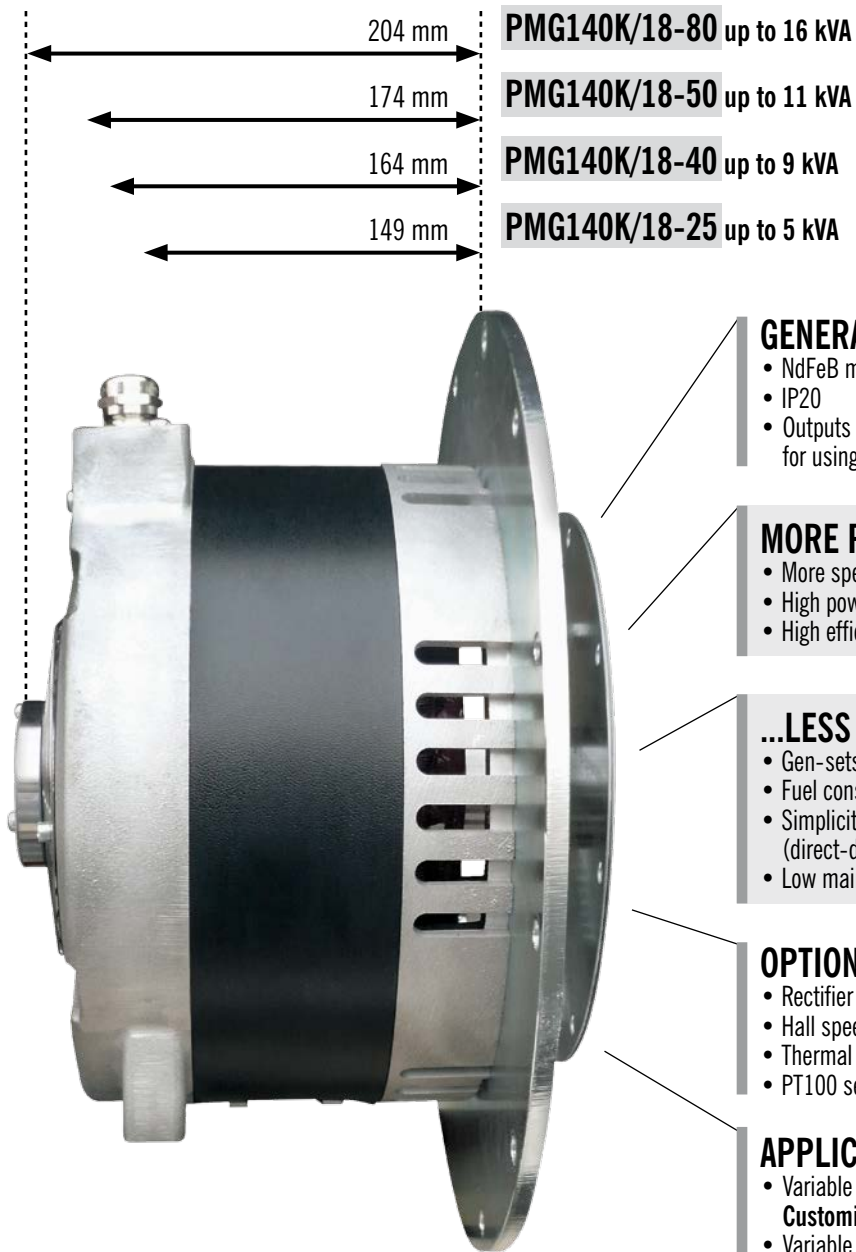

PMG140K

COMPACT PERMANENT MAGNET GENERATORS FOR VARIABLE SPEED



GENERAL FEATURES

- NdFeB magnets, radial flux, 18 poles
- IP20
- Outputs in AC/3-phase (F class), adaptable for using with AC/AC or AC/DC converter

MORE POWER...

- More speed = more power (variable speed)
- High power on weight ratio
- High efficiency



...LESS COSTS!

- Gen-sets can be more compact, smaller, lighter
- Fuel consumption can be reduced
- Simplicity in construction and assembling (direct-drive engine coupling)
- Low maintenance

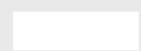

OPTIONALS & ACCESSORIES

- Rectifier bridge (loose)
- Hall speed sensors
- Thermal sensors
- PT100 sensors

APPLICATIONS

- Variable speed (medium/high) **1000 ÷ 3600 rpm**
Customized speeds on request
- Variable speed generating sets and DC generators, coupled to endothermic engines (examples: lighting towers, APU, military, marine, hybrid systems)

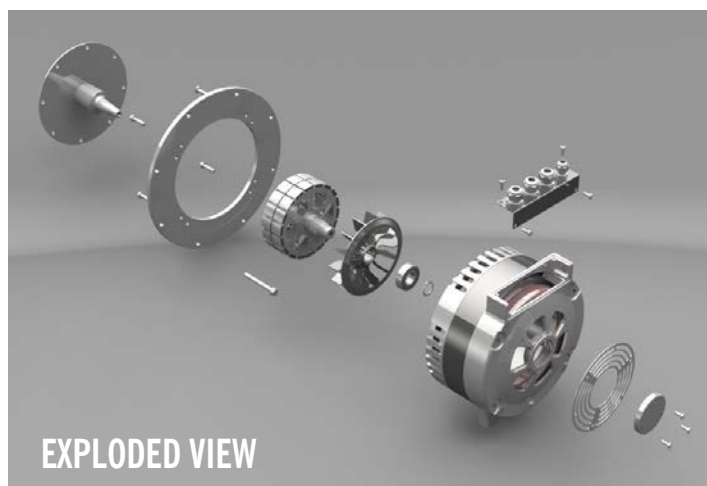

TYPICAL APPLICATIONS BLOCK DIAGRAMS

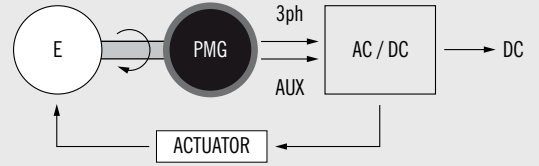
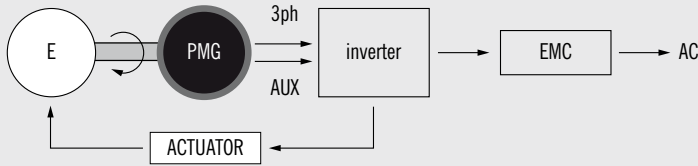

 Supplied by SOGA

For DC outputs: power derating of approx. 15%

POWER & EFFICIENCY CURVES 3ph load, power factor 1, voltage drop no load - full load = 20%

— Power AC KVA — Efficiency %

PMG140K/18-25

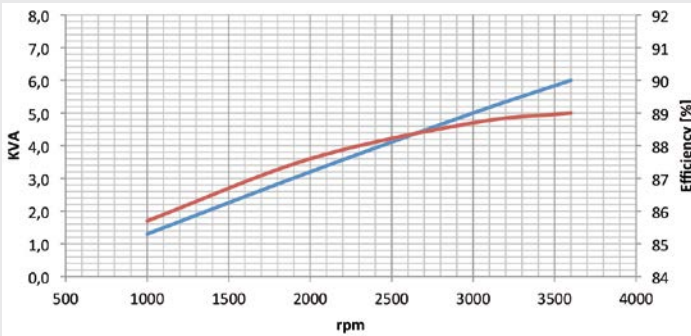

RPM	power AC	efficiency
	KVA	%
1000	1,3	85,7
2000	3,2	87,6
3000	5	88,7
3600	6	89

PMG140K/18-40

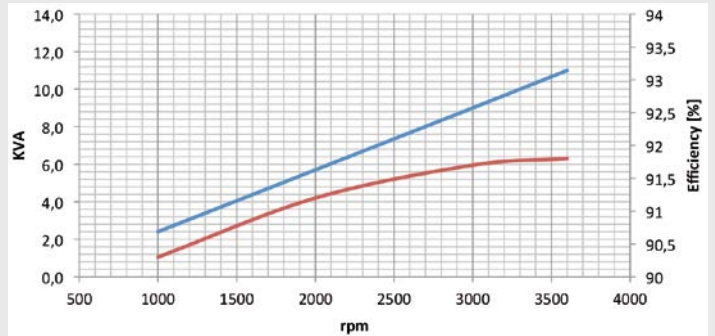

RPM	power AC	efficiency
	KVA	%
1000	2,4	90,3
2000	5,7	91,2
3000	9	91,7
3600	11	91,8

PMG140K/18-50

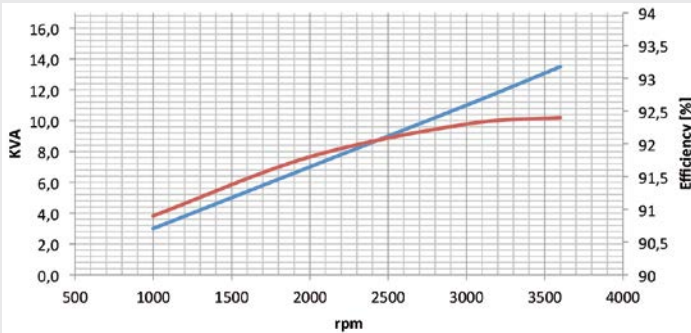

RPM	power AC	efficiency
	KVA	%
1000	3	90,9
2000	7	91,8
3000	11	92,3
3600	13,5	92,4

PMG140K/18-80

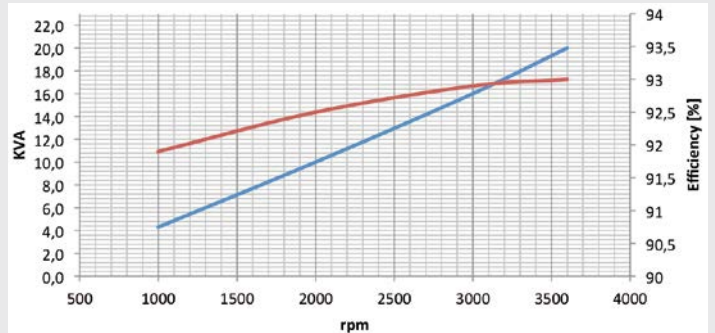

RPM	power AC	efficiency
	KVA	%
1000	4,3	91,9
2000	10	92,5
3000	16	92,9
3600	20	93

OVERALL DIMENSIONS

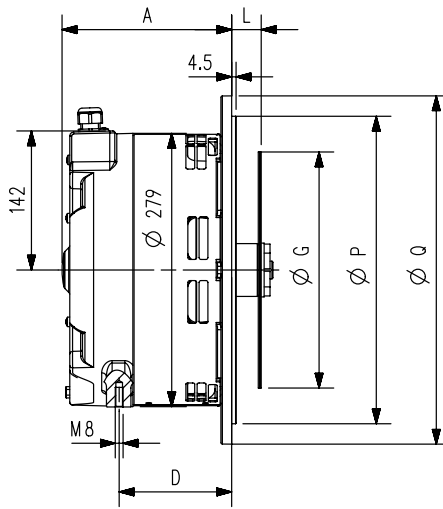
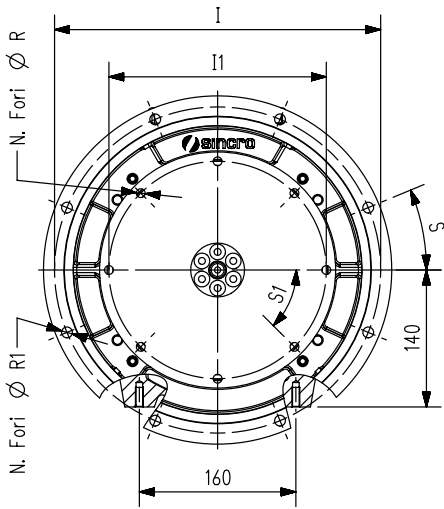

SAE

DISK JOINT	FLANGE		G	I1	L	R	HOLES	S1
	5	4						
6,5	•	•	215,9	200	30,2	9	6	60°
7,5	•	•	241,3	222,2	30,2	9	8	45°
8	•	•	263,5	244,5	62	11	6	60°
10	•	•	314,3	295,3	53,8	11	8	45°
P	314,3	362						
Q	358	405						
I	333,4	381						
S	22°30'	15°						
R1	11	11						
holes	8	12						

model	A [mm]	D [mm]	weight [kg]
PMG140K/18-25	149	90	18,4
PMG140K/18-40	164	105	21
PMG140K/18-50	174	115	23,8
PMG140K/18-80	204	145	32,1

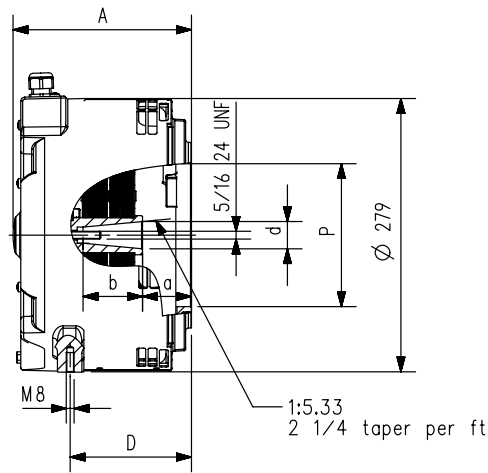
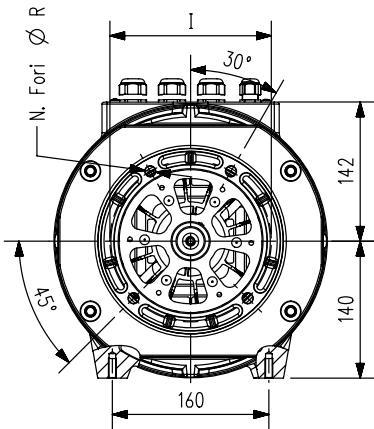

J609b

shaft			
cone	d	a	b
25,4	25,4	63,5	48
35	27,9	50	60,8

flange			
I	p	holes	R
165	146,1	4	11
197	163,6	4	11
197	177,8	4	11

model	A [mm]	D [mm]	weight [kg]
PMG140K/18-25	158	99	15,5
PMG140K/18-40	173	114	18,4
PMG140K/18-50	183	124	20,9
PMG140K/18-80	213	154	29,2



Soga S.p.A.
Via Della Tecnica, 15 • 36075 Montecchio Maggiore (VI) • ITALY
Phone +39 0444 747700 • Fax +39 0444 499269
sales.soga@sogaenergyteam.com

www.sogaenergyteam.com

