

Converters and alternators
for concrete vibrators





MADE IN ITALY

 **soga**[®]

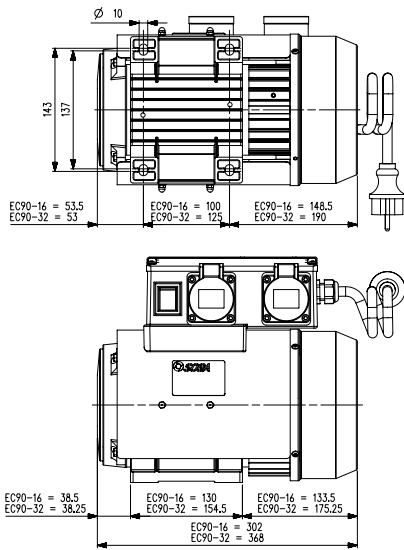
Rotating converters for high frequency concrete vibrators generators

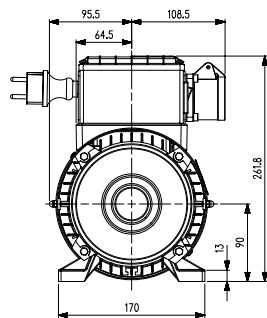

EC90-16 / EC90-32



EC90-45

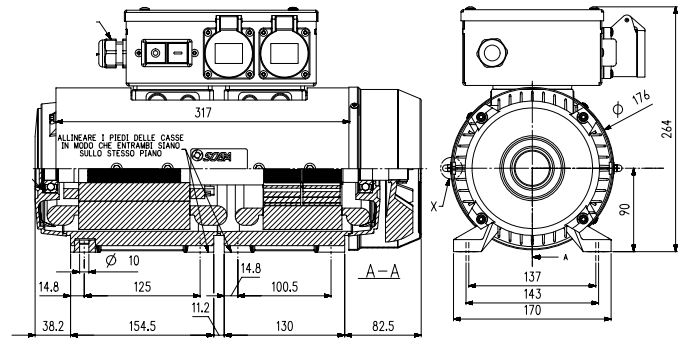

general features

- > Asynchronous motor + high frequency permanent magnet generator
- > EN 600034-1
- > Insulation class F
- > IP44
- > Input voltage (electric motor): single-phase 230V/50Hz or three-phase 400V/50Hz
- > Output voltage (generator): three-phase 42V/200Hz
- > Aluminium housing with steel protection carter painted in black with epoxy powders
- > ABS shock-resistant box on single-phase models equipped with:
On/off switch + 2x 32A sockets + 1,5-mt-cable + single-phase schuko plug
- > Metal box on three-phase model equipped with:
2 x 32A sockets + 1,5-mt-cable + three-phase CEE plug

models	asynchronous motor		permanent magnet generator				mass (Kg)
	kW (P1)	V - Hz	kVA (50Hz)	I (42V)	V - Hz	32 A sockets	
EC90-16	1,5	1 phase 230 - 50	1,1	16 A	42 - 200	2	17
EC90-32	3	1 phase 230 - 50	2,2	32 A	42 - 200	2	25
EC90-45	4,5	3 phase 400 - 50	3,5	45 A	42 - 200	2	30

Rotating converters with protection case

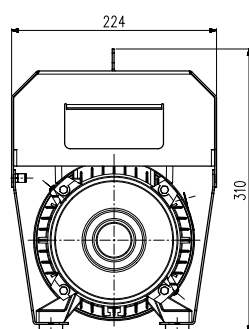
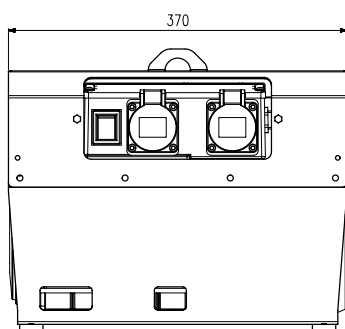

general features

POKERWATT is the new series extending SOGA range of EC electroconverters into a new, **easy Plug & Play solution** for professional heavy duty jobs.

PowerWatt's are rotating converters equipped with a 2-mm-thick case made of steel, steel, enhancing their steadiness, durability, portability, mechanical strength and protection against accidental hits and concrete falls.

Manufactured in Italy in SOGA factory by using our available technology (laser cutting, sheet metal punching equipment), they are supplied with following key-points:

- > Single or Three-phase AC input
- > V42/200Hz high frequency permanent magnet generator output
- > Neodimium magnets for long life high electrical performances
- > Easy to transport and to handle
- > Epoxy powder painting for the case
- > PowerWatts can be individually packed in carton box.

models	asynchronous motor		permanent magnet generator				carton box (mm)			q.ty/pallet	total mass (Kg)
	kW (P1)	V - Hz	kVA (50Hz)	I (42V)	V - Hz	32 A sockets	H	W	L		
PW-16	1,5	1 phase 230 - 50	1,1	16 A	42 - 200	2	320	265	400	24	21
PW-32	3	1 phase 230 - 50	2,2	32 A	42 - 200	2	320	265	400	24	29
PW-45	4,5	3 phase 400 - 50	3,5	45 A	42 - 200	2	400	400	600	8	35

Engine-driven high frequency alternators for concrete vibrators

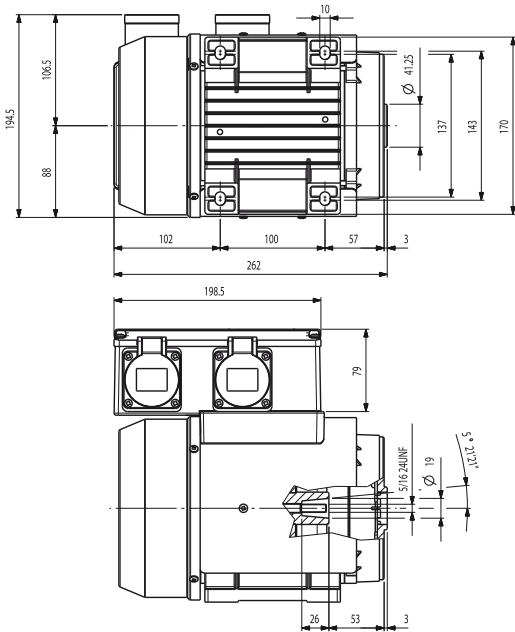

MC90

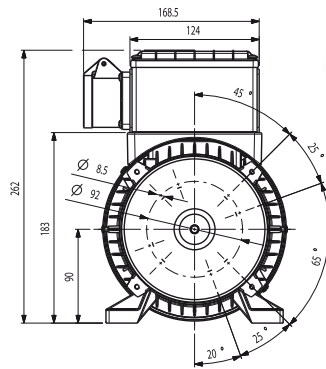

general features

- › High frequency permanent magnet generator
- › EN 600034-1
- › Insulation class F
- › IP44
- › Output voltage: three-phase 42V/200Hz
- › Aluminium housing with steel protection carter painted in black with epoxy powders
- › ABS shock-resistant box on single-phase models equipped with 2x 32A sockets
- › Coupling for engines J609a cone 19

models	permanent magnet generator				mass (Kg)
	kVA (50Hz)	I (42V)	V - Hz	32 A sockets	
MC90-16	1,1	16 A	42 - 200	2	10,9
MC90-32	2,2	32 A	42 - 200	2	12,5
MC90-45	3,5	45 A	42 - 200	2	13,3

WARRANTY POLICY

Please take note that the products described in this catalogue are intended for manufacturers and not for end users. SOGA SpA does not supply any kind of warranty nor spare parts to end users. Please see our general terms of supply on our website: sogaenergyteam.com/general-terms-of-supply



Soga S.p.A.
Via della Tecnica, 15 • 36075 Montecchio Maggiore (VI) • ITALY
Phone +39 0444 747700
sales.soga@sogaenergyteam.com

www.sogaenergyteam.com

